

Specifications

Output Power HP (kW)	5 (3.7)
Phase	3 Phase
Pole	4 Pole
Frame Number	112M

Degrees of Protection	IP 55
Enclosure Construction	Totally-enclosed Fan-cooled
Thermal Class	Class F (155 °C)

Alignment	Horizontal
Frame Material	Steel plate

Power Transmission	Direct-couple or Belt Driven
Direction of Rotation	Counterclockwise (CCW) viewed from shaft-end side

Connection Type	Terminal Block (6 Leads)
Coating Colour	Munsell N5.5 (Gray)
Conformed Standard	IEC 60034-1 & JEC-2137-2000

Voltage & Frequency	LT Type	
	220/380~415V	50Hz
	220/440V	60Hz

* The perpendicular variation of tolerance for the shaft center is $\begin{matrix} 0 \\ -0.5 \end{matrix}$

Dimensions (mm)

Motor														
A	B	C*	D	E	F	G	H	I	J	K	L	M	ML	N
181	138	112	228	95	70	6.5	226	253	40	45	381	230	242	180

Motor			Terminal Box				Shaft End						
X	XB	Z	KA	KG	KD	KL	Q	QK	R	S	T	U	W
4	70	12	69	87	PF 3/4	182	60	45	200	28 j6	7	4	8

Bearing No.		Approximated Weight (kg)	Approximated Packing Dimensions (LxWxH)	Gross Weight (kg)
Drive End	Opposite			
6207ZZ	6206ZZ	36	477 x 399 x 315	42

Connection & Connection Diagram

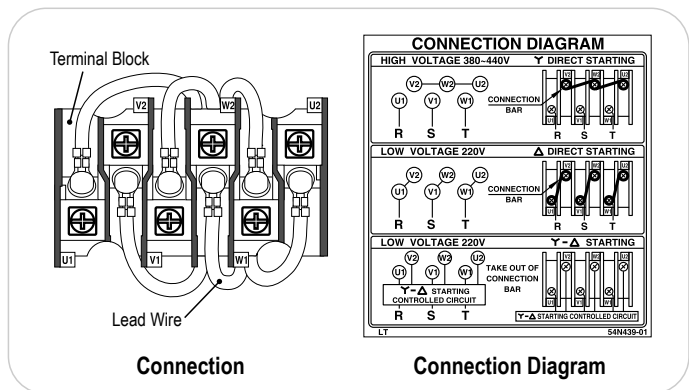

Circumstance Conditions

Ambient Temperature	-20 ~ +40°C
Ambient Humidity	95% RH or less
Operating Altitude	Less than 1,000m above sea level
Environment	No bursting / erosive gas or vapor

Motor Characteristics

Type	Hz	V	50% Load			75% Load			100% Load				Torque(%)		Is (A)	Inertia GD ² (kg-m ²)	
			(A)	Eff(%)	PF(%)	(A)	Eff(%)	PF(%)	(A)	Eff(%)	PF(%)	Speed (r/min)	Torque (kg-m)	Ts			Tm
LT	50	220	8.35	0.85	0.68	10.7	0.86	0.79	13.5	0.86	0.83	1420	2.54	266	289	80.0	0.056
		380	4.82	0.85	0.68	6.20	0.86	0.79	7.81	0.86	0.83	1420	2.54	266	289	46.2	
		415	5.17	0.84	0.60	6.24	0.85	0.73	7.61	0.85	0.79	1430	2.52	316	344	50.5	
	60	220	7.54	0.84	0.77	10.1	0.86	0.84	13.2	0.85	0.87	1710	2.11	223	247	75.0	
		440	4.56	0.81	0.66	5.55	0.87	0.75	6.94	0.86	0.81	1730	2.08	298	335	50.1	